

R4 AIS

Class A

Transponder System



The International Maritime Organisation's (IMO) carriage requirement for Automatic Identification System (AIS) will substantially enhance safety at sea giving a ship's Officer of the Watch (OOV) an improved situation awareness for collision avoidance. AIS will also provide better land-based services for mariners from VTS as well as improved security, environment and safety in ports and along coasts. AIS uses the Swedish invented and patented technology SOTDMA (Self-Organised Time Division Multiple Access) which allows seamless operation worldwide. Saab TransponderTech is the world leader in the field of AIS with several years of experience in designing and manufacturing transponders based on the SOTDMA technology. Our R4 AIS Vessel Transponder is the fourth generation of Saab AIS, using the latest technology to achieve the highest performance and reliability. The R4 Class A Transponder System is type-approved with wheelmark and complies with all international standards for AIS ship systems.

The R4 AIS Class A Transponder System provides you with the following high performance main features:

- Broadcast of Dynamic, Static, Voyage Related information and Short Safety Related Data.
- Standardized interface for connection to ship sensors e.g. GNSS, Gyro, Turn indicator, ECDIS, ECS, ARPA, Radar and Speed Log.
- High resolution 6" graphic day and night display providing a radar like presentation of up to 500 targets in the vicinity of own ship. Situation display with capability to show vessels by bearing, range, name and call sign. Messaging display for generation and presentation of safety related text messages. Configuration and engineering mode to manage the system without any extra tools. Integrated in to the display is also the mandatory pilot plug so that installation cost can be reduced.
- Future upgrades possible without hardware changes using fully integrated DSP solution.
- VHF transceiver with one transmitter, three receivers.
- Internal 12 channel backup GPS ready to upgrade with DGPS, WAAS and EGNOS capability.
- Easy to install and meets IMO installation recommendations.
- Easy to operate with user-friendly Human Machine Interface developed by practicing mariners.
- Channel management capability for areas operating on AIS frequencies other than the standard worldwide allocated AIS frequencies.
- Possibility to generate Long Range AIS reply over SATCOM equipment e.g. Inmarsat C.
- Plug and play

Optional

- DGNS capability (New DGNS standard).

Ships equipped with an AIS transponder can receive transmitted messages from other ships within VHF range, and plot the position of the ships with its speed, name, call sign, heading, course over ground etc. on the AIS display and/or external plotting aids. This means that every ship within VHF radio coverage may be automatically plotted on the bridge display systems. Saab provides the world with the AIS solutions it requires, both at sea and on land.

The new generation AIS Transponder from Saab provides you with the optimal AIS system for use on all types of ships. The R4 AIS System is fully in compliance with international regulation and standards as well as with national and class requirements. The installation is easy and can in most cases be performed in less than one day. The system has a proven high availability and reliability due to the low power consumption, giving low internal heat radiation. This will guarantee the performance and ensure long trouble free operation. The R4 AIS Transponder consists of a radio transceiver unit, a GPS receiver, a controller unit and a separate display unit.

The transceiver contains three independent VHF receivers (two TDMA tunable receivers, and one DSC receiver), and one transmitter. The transmitter alternates its transmissions between the two operating TDMA channels, and can also be used to reply to a DSC interrogation (ITU-R M.825-3, Annex 1). The internal GPS receiver provides accurate time synchronization. It can also be used as a back-up source of Ship's Speed-Over-Ground (SOG), Course-Over-Ground (COG) and position information in case of failure of main sensors. The controller creates and schedules data packets for transmission based on Dynamic, Static and Voyage Related data as defined in the IMO performance standard.



The R4 AIS Transponder can easily be interfaced to the required sensors on the bridge e.g. Gyro, and GNSS. It has already been tested and interfaced with most external navigation presentation systems on the market (Radar, ECS/ECDIS). The R4 is prepared for connection to Long-Range systems like Inmarsat C. It has a user-friendly interface for plotting of other ships on a radar like display. It can also display information about other vessels sorted by bearing or by range. The display also handles the sending/receiving of messages.

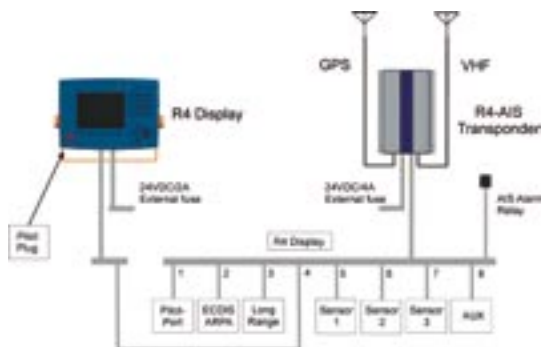

EQUIPMENT LIST (STANDARD)

- R4 AIS Transponder
- R4 Display unit
- Integrated Pilot plug
- Transponder connecting cable 2m
- Display unit connecting cable 2m
- Transponder power cable 2m
- Display unit power cable 2m
- Alarm relay
- Installation and operation manuals
- Gimble Mounting

OPTIONAL

- Junction box
- GPS Antenna
- VHF Antenna
- Connectors
- Power converter
- Gyro converter
- Flush Mounting

<p>Physical</p> <p>Transponder: Size WxHxL 144x85x226 mm, Weight: 2,3 kg</p> <p>Display Size WxHxL 102x207x270 mm, Weight: 1.1 kg</p> <p>Power</p> <p>Input 24V DC (230/110 vac with converter)</p> <p>Power consumption Transponder 15W (50W peak) Display 7,5W</p> <p>GPS Receiver (AIS internal)</p> <p>Receiver 12ch (Ready for DGPS) Frequency L1(1575,42 MHz) Update rate: 1Hz Position accuracy (SA off) Position <1 m DGPS (CEP) Position <16 m GPS (CEP)</p> <p>Electrical Interfaces</p> <table border="1"> <tr><td>8 data ports</td><td>RS422</td></tr> <tr><td>Port</td><td>Deafault speed (bps)¹</td></tr> <tr><td>Pilot</td><td>In/Out 38400</td></tr> <tr><td>ECDIS</td><td>In/Out 38400</td></tr> <tr><td>Long Range</td><td>In/Out 9600</td></tr> <tr><td>Sensor 1</td><td>In 4800</td></tr> <tr><td>Sensor 2</td><td>In 4800</td></tr> <tr><td>Sensor 3</td><td>In 4800</td></tr> <tr><td>Aux</td><td>In 9600</td></tr> <tr><td>Display</td><td>In/Out 57600</td></tr> </table>	8 data ports	RS422	Port	Deafault speed (bps) ¹	Pilot	In/Out 38400	ECDIS	In/Out 38400	Long Range	In/Out 9600	Sensor 1	In 4800	Sensor 2	In 4800	Sensor 3	In 4800	Aux	In 9600	Display	In/Out 57600	<p>Connectors</p> <p>Transponder data port: 50 pin D-sub (M) Transponder power: 9 pin D-sub (M) GPS antenna connector: TNC female (50Ω) VHF antenna connector: BNC female (50Ω) Display data port: 18 pole Conxall Maxi-Con-X Display power: 3-pole Mini-Con-X Power and data interfaces to be connected on rail terminals or in junction box</p> <p>Cables (recommended)</p> <p>Antenna, VHF and GPS RG214/U For sensors e.g Gyro RFE-HFI 2x2x0,75 mm² Transponder to Display RFE-HFI 4x2x0,75 mm² Power cables Transponder LKM-HF 3x2,5 mm² and display</p> <p>VHF Transceiver</p> <table border="1"> <tr><td>Frequency</td><td>156–163MHz</td></tr> <tr><td>Output power</td><td>2/12,5W (±1,5dB)</td></tr> <tr><td>Channel bandwidth</td><td>25/12,5kHz</td></tr> <tr><td>Channel step</td><td>12,5kHz</td></tr> <tr><td>Bit rate</td><td>9600bps</td></tr> <tr><td>Intervals between position reports</td><td>1–180s</td></tr> <tr><td>Modulation</td><td>FM-GMSK/GFSK</td></tr> <tr><td>Transmitter</td><td>1</td></tr> <tr><td>Receivers</td><td>3</td></tr> <tr><td>DSP Based Transceiver</td><td></td></tr> <tr><td>Sensitivity</td><td>< -107dBm</td></tr> </table>	Frequency	156–163MHz	Output power	2/12,5W (±1,5dB)	Channel bandwidth	25/12,5kHz	Channel step	12,5kHz	Bit rate	9600bps	Intervals between position reports	1–180s	Modulation	FM-GMSK/GFSK	Transmitter	1	Receivers	3	DSP Based Transceiver		Sensitivity	< -107dBm	<p>Environmental</p> <p>Protected environment (IEC 60945) Operating temperature : -15° to +55°</p> <p>Compliant with the following Standards</p> <p>IMO Performance Standard for AIS (MSC 74(69) Annex 3) ITU-R M. 1371-1 IEC 61993-2 (Standard for Class A mobiles) IEC 61162-1/2 Edition 2 (NMEA 0183, Version 3.0) INPUT: (ABM, ACA, ACK, AIQ, AIR, BBM, DTM, GBS, GGA, GLL, GNS, GSA, GSV, HDT, LRF, LRI, OSD, RMC, ROT, SSD, VBV, VSD, VTG, ZDA) OUTPUT: (ABK, ACA, ACS, ALR, LRF, LRI, LR1, LR2, LR3, SSD, VDM, VDO, VSD, TXT)</p> <p>IEC 60945 (ed 4) IALA Technical clarifications on ITU R M.1371-1 IALA Guidelines on AIS</p> <p>Approval</p> <p>Type approved Wheelmark CE Approval</p> <p>¹Configurable from 1200–115200bps</p> <p>Membership Organisations</p> <p>Specifications subject to change without notice. Document id: 7000100-087A</p>
8 data ports	RS422																																											
Port	Deafault speed (bps) ¹																																											
Pilot	In/Out 38400																																											
ECDIS	In/Out 38400																																											
Long Range	In/Out 9600																																											
Sensor 1	In 4800																																											
Sensor 2	In 4800																																											
Sensor 3	In 4800																																											
Aux	In 9600																																											
Display	In/Out 57600																																											
Frequency	156–163MHz																																											
Output power	2/12,5W (±1,5dB)																																											
Channel bandwidth	25/12,5kHz																																											
Channel step	12,5kHz																																											
Bit rate	9600bps																																											
Intervals between position reports	1–180s																																											
Modulation	FM-GMSK/GFSK																																											
Transmitter	1																																											
Receivers	3																																											
DSP Based Transceiver																																												
Sensitivity	< -107dBm																																											

SAAB TRANSPONDERTECH AB

P.O. Box 4113, SE-171 04 Solna, Sweden
 Phone: +46 13 18 80 00 · Telefax: +46 8 627 49 49
 Home page: www.transpondertech.se
 E-mail: info@transpondertech.se
 A subsidiary within the Saab Group

